

FAR one® TOOLS



RB 1800D
Simple Machine

© FAR GROUP EUROPE

113395-4-K-20220420

- FR** *Dégauchisseuse* (Notice originale)
- EN** *Jointer* (Original manual translation)
- DE** *Elektrohobel* (Übersetzung aus dem Original-Anleitung)
- ES** *Pialla eléctrica* (Traducción del manual de instrucciones originale)
- IT** *Pialla a filo* (Traduzione dell'avvertenza originale)
- PT** *Maquina de Aplainar* (Tradução do livro de instruções original)
- NL** *Elektrische Schaafmachine* (Vertaling van de originele instructies)
- EL** **ΗΛΕΚΤΡΙΚΗ ΠΛΕΑΝΗ** (ΜΕΤΑΦΡΑΣΗ ΑΠΟ ΤΙΣ ΠΡΩΤΟΤΥΠΕΣ ΟΔΗΓΙΕΣ)
- PL** *Strugarka Elektryczna* (Tłumaczenie z oryginalnej instrukcji)
- FI** *Sähköhöylä* (Käännös alkuperäisestä ohjeet)
- SV** *Elhyvel* (Översättning från originalinstruktioner)
- BU** *Електрическо ренде* (Превод на оригиналната инструкция)
- DA** *Elektrisk høvl* (Oversættelse fra oprindelige brugsanvisning)
- RO** *Rindea electric* (Traducere din instrucțiunile originale)
- RU** *Электрический строг* (Перевод с оригинальной инструкции)
- TU** *Elektrikli rende* (Orijinal talimatlar çeviri)
- CS** *Srovnávací* (Překlad z originálního návodu)
- SK** *Porovnávacie* (Preklad z originálneho návodu)
- HE** *תורוקמ תוארומה סוגרת* (תילמשח העוצקמ)
- AR** *تامي لصل أا تام يلع تل نم قم جرتا* (ي ابرك رجم)
- HU** *Elektromos gyalu* (Fordítás az eredeti utasítások)
- SL** *Elektrini nadrezkar* (Prevod iz izvornih navodil)
- ET** *Freesimispink* (Tõlge originaal juhiseid)
- LV** *Stacionārā ēvele* (Tulkojumā no instrukcijas oriģinālvalodā)
- LT** *Stacionarus oblius* (Vertimas iš originalių instrukcijos)
- HR** *Mistrija* (Vertimas iš originalių instrukcijos)

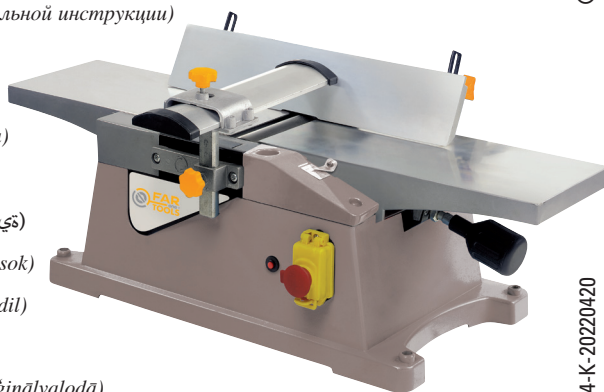

fartools.com

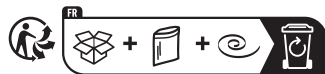
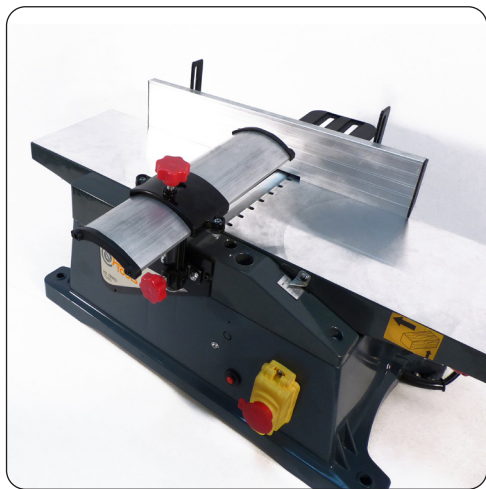
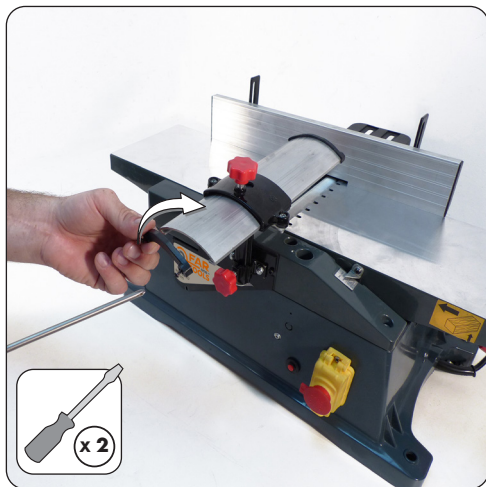
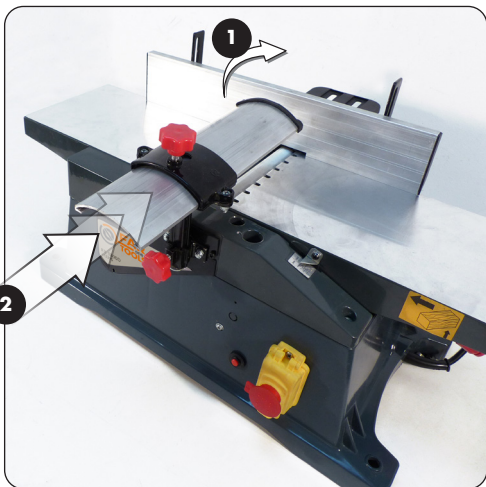

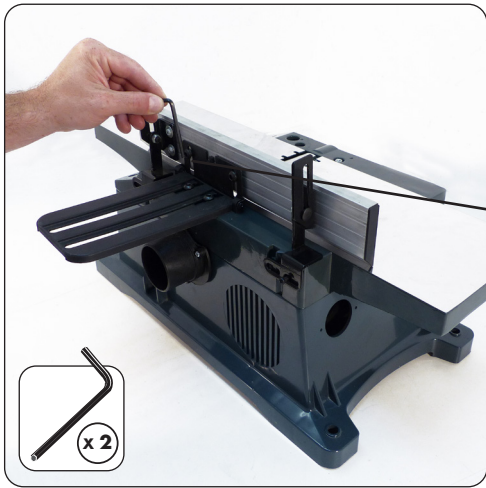
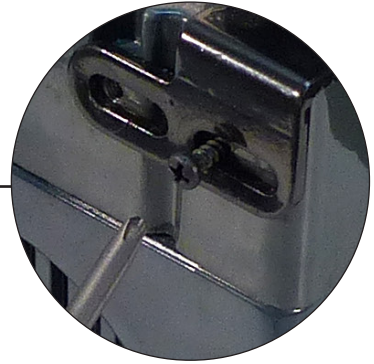

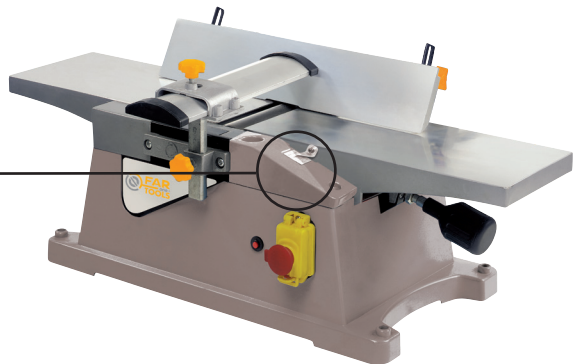
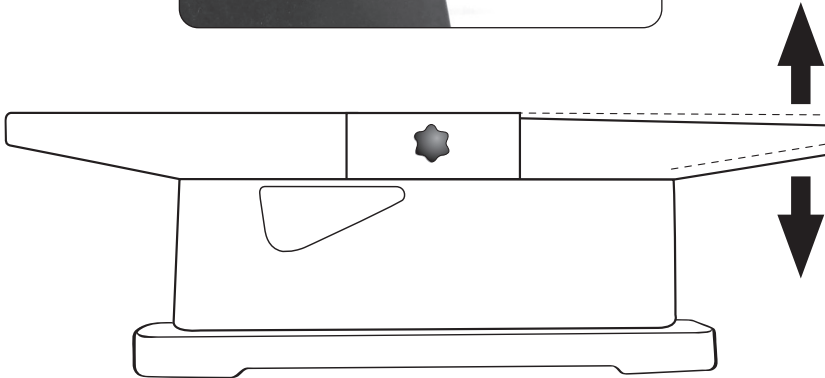
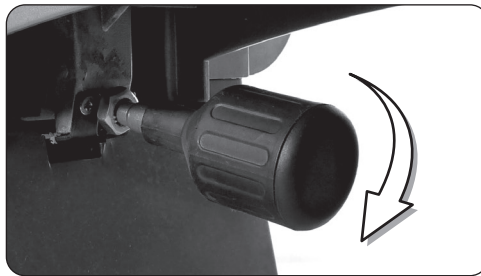

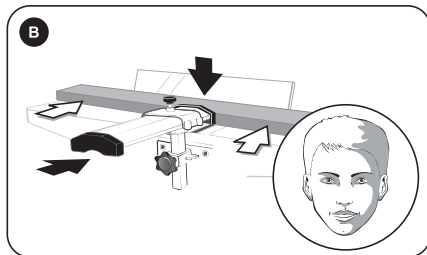
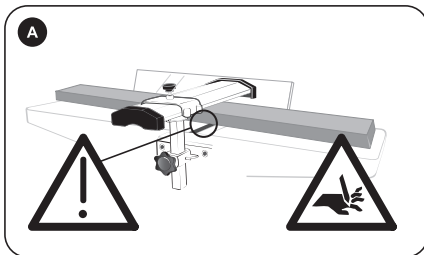
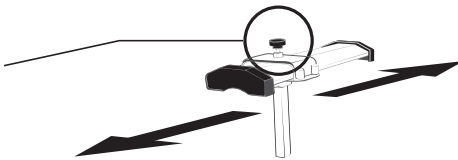
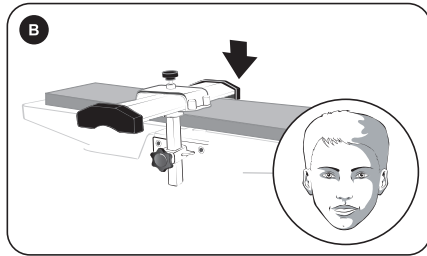
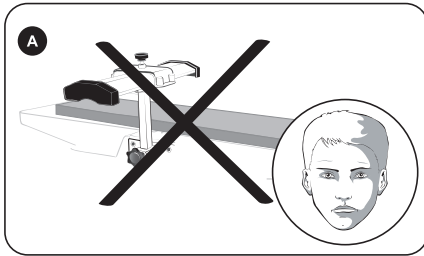
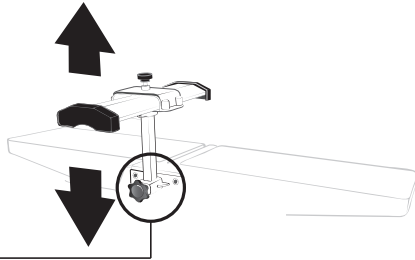
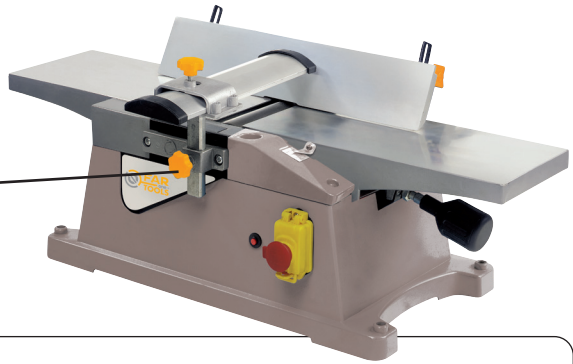
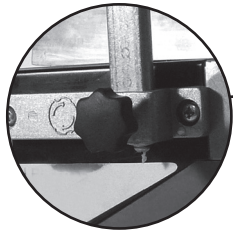

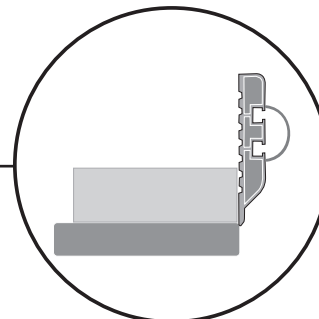
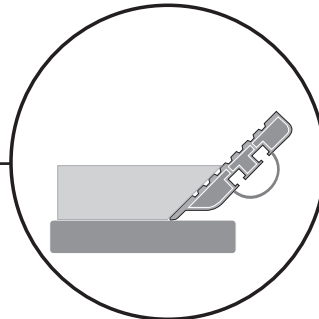
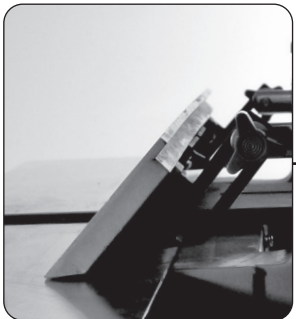
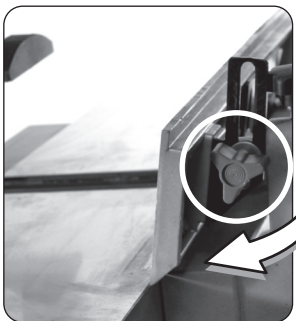
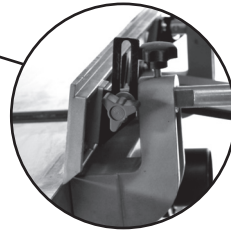
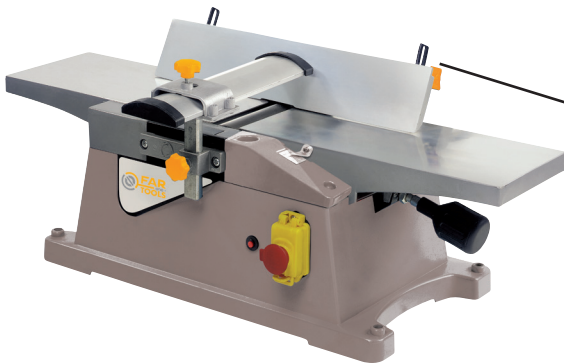



ATTENTION ! / WARNING !

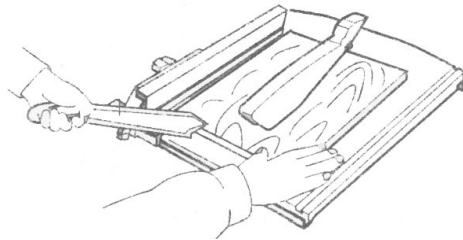
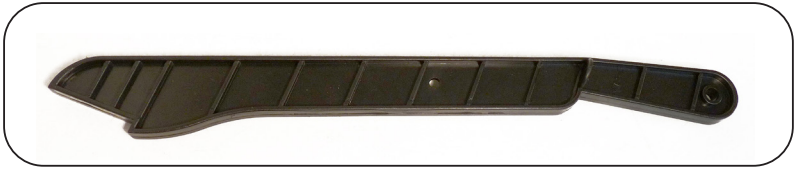
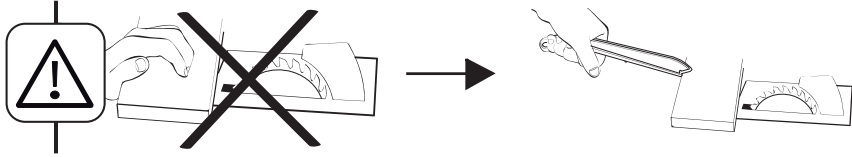

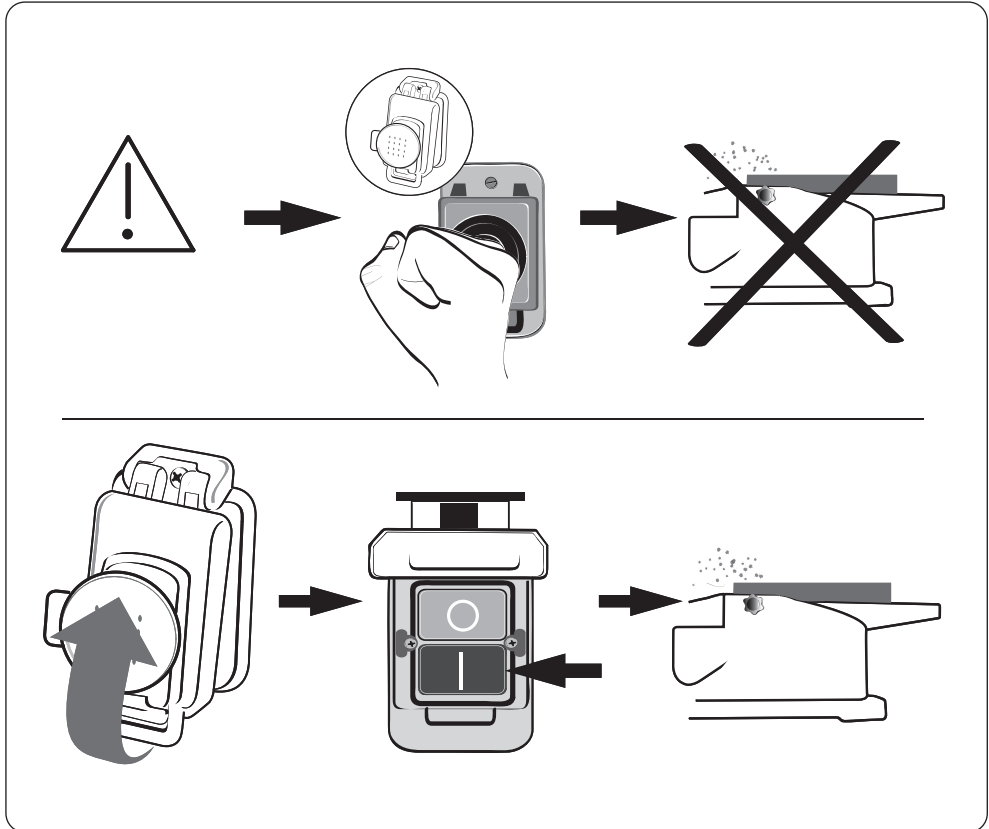
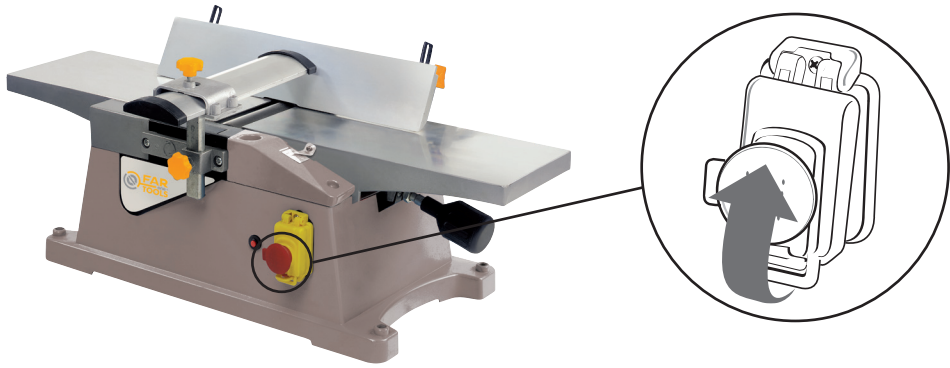



Protection thermique - Thermische beveiliging - La protección térmica -
A proteção térmica - Protezione termica - Thermal protection

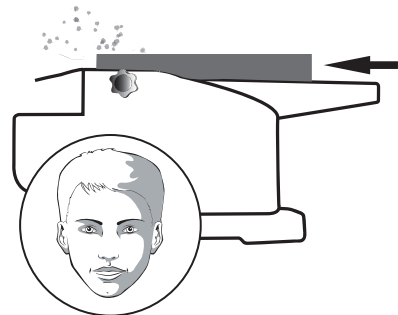
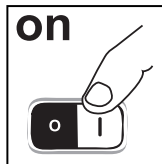
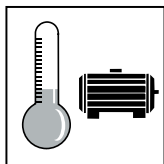
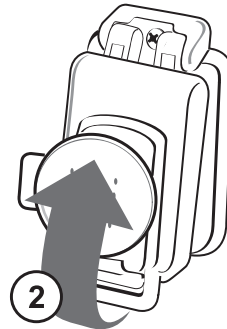
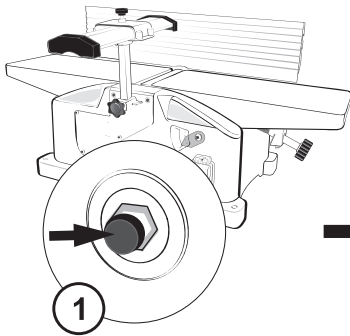
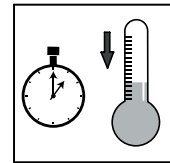
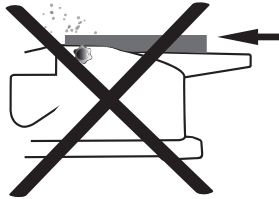
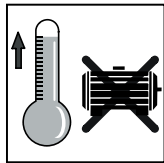
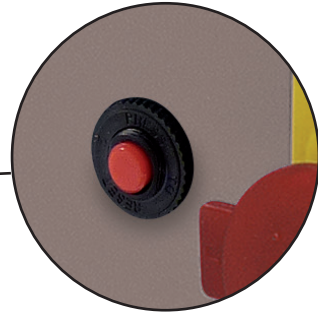
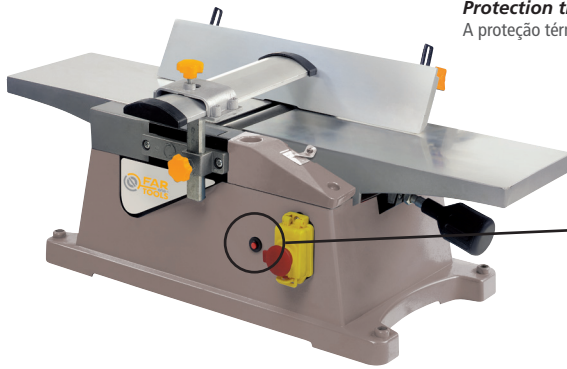

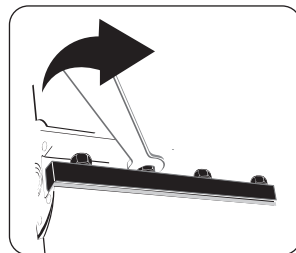
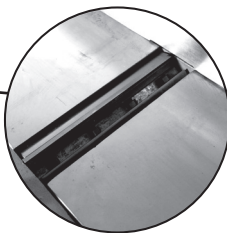
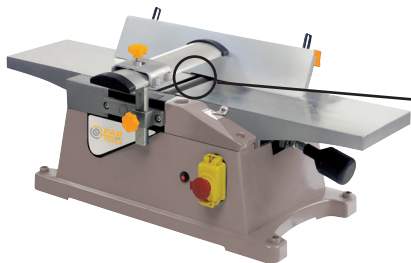



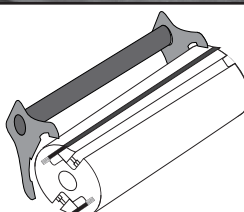
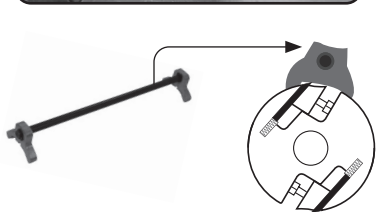
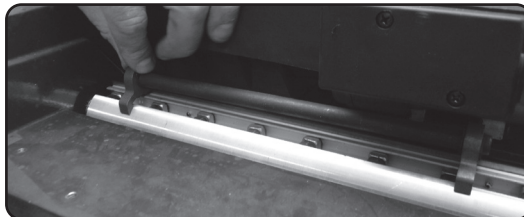
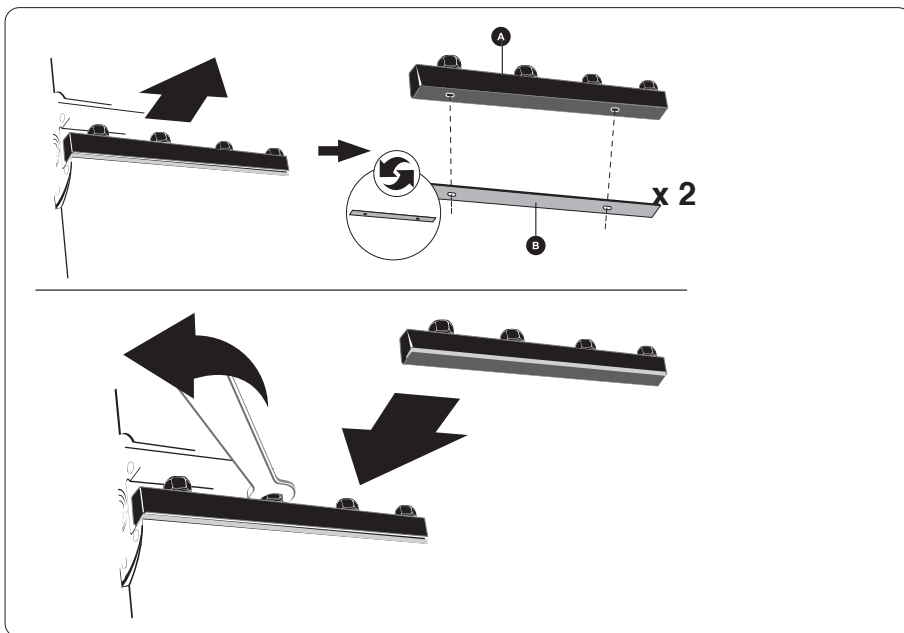

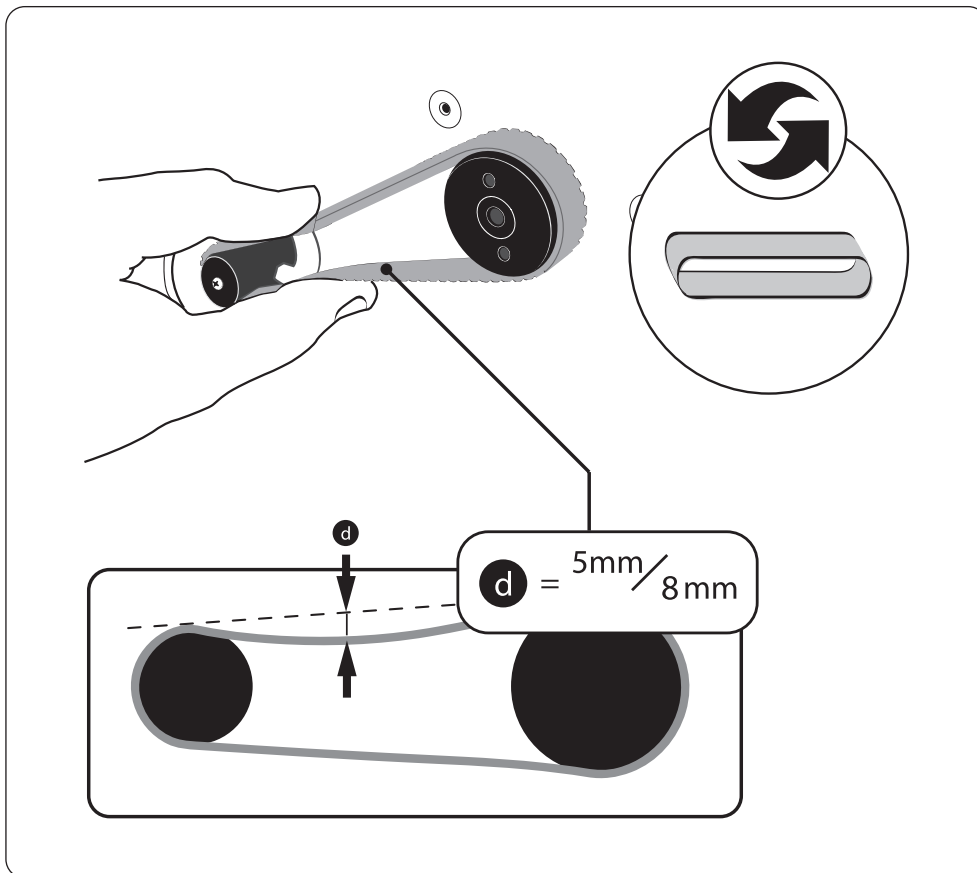
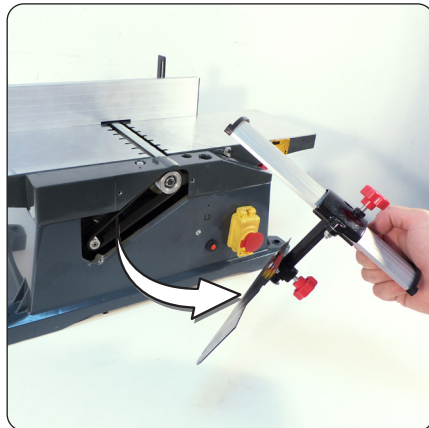
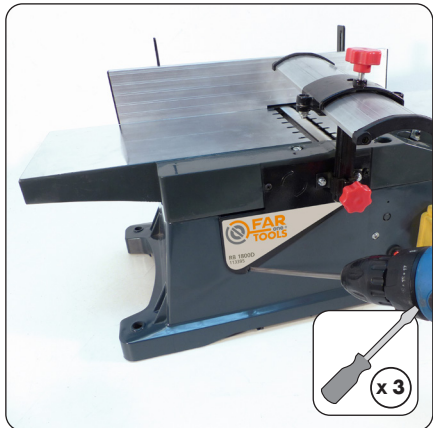
113899
155 x 20 x 3 mm
Lame - Blade - Lama
Cuchilla - Lâmina - Plaatje

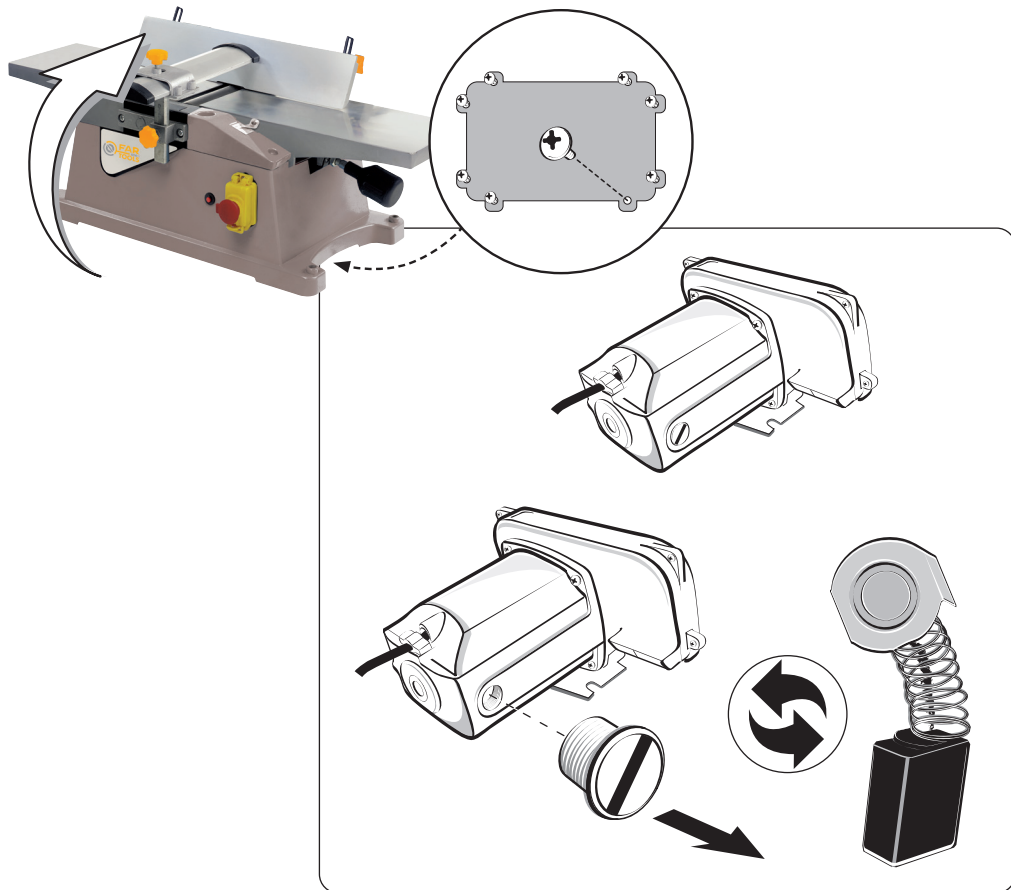
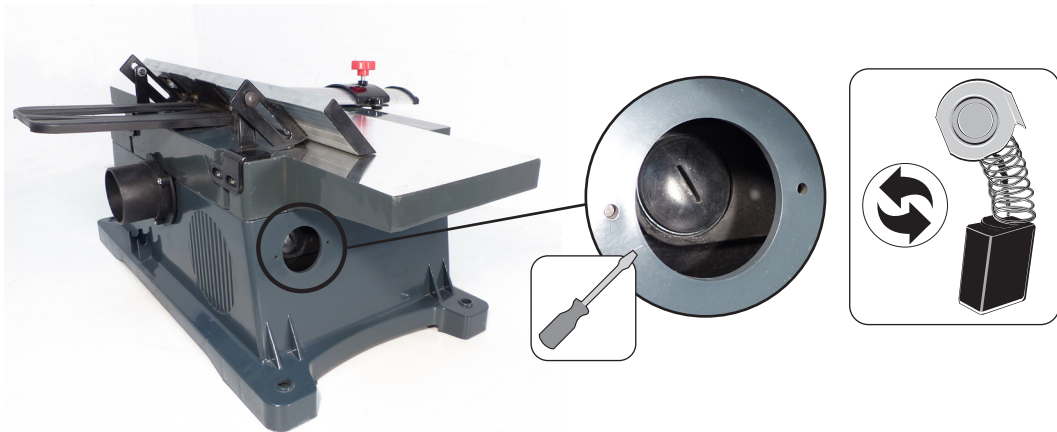







	<p>Tension et fréquence assignée: Nominal frequency and power: Nennspannung und Nennfrequenz : Tensión y frecuencia fijada: Tensione e frequenza assegnata: Tensão e frequência fixa: Aangewezen spanning en frequentie: ΟΝΟΜΑΣΤΙΚΗ ΤΑΣΗ ΚΑΙ ΣΥΧΝΟΤΗΤΑ: Napięcie i częstotliwość przydzielona: Jännite ja määrätty taajuus: Angiven spänning och frekvens: Anført spænding og frekvens: Tensiune și frecvență de lucru:</p>	<p>Заданное напряжение и частота: Tahsis gerilimi ve frekans: Stanovené napětí a frekvence: Stanovené napätie a frekvencia: Merkespenning og merkefrekvens: الفصلطية والذبذب الجبرمجة. Névleges feszültség és frekvencia: Napetost in določena frekvenca: Консумирано напрежение и частота : Määratud pinge ja sagedus Nustatyta įtampa ir dažnis Noteiktais spriegums un frekvence. Napon i nazivna frekvencija:</p>	230 V ~ 50 HZ
	<p>Puissance assignée: Nominal power: Nennleistung: Potencia fijada: Potenza assegnata: Potência assinada: Onbelast toerental: ΟΝΟΜΑΣΤΙΚΗ ΙΣΧΥΣ: Prędkość na biegu jałowym: Teho: Angiven effekt: Anført styrke: Putere de lucru:</p>	<p>Заданная мощность: Tahsis edilen güç: Stanovený příkon: Predpísaný výkon: Merkeeffekt: القدرة الجبرمجة. Névleges teljesítmény : Določena jakost: Консумирана мощност: Määratud võimsus. Nustatyta galia Noteiktā jauda Nazivna snaga:</p>	1800 W
	<p>Vitesse à vide: No-load speed: Leerlaufdrehzahl: Velocidad vacía: Velocità a vuoto: Velocidade no vácuo: Leerlaufdrehzahl: ΤΑΧΥΤΗΤΑ ΑΔΡΑΝΕΙΑΣ: Prędkość bez bciążenia: Tyhjäkäyntinopeus Tomgångshastighet: Hastighed i ubelastet tilstand: Viteza în gol:</p>	<p>Скорость вращения на холостом ходу: Boşalma hızı: Rychlost naprázdno: Rýchlost pri chode naprázdno: Tomgangshastighet: السرعة على الفارغ. Üres sebesség: Prosti tek: Скорост на празни обороти: Kiirus tünikäigul Tuščio prietaiso greitis Tukšgaitas ātrums Brzina praznog hoda:</p>	12000 min ⁻¹
	<p>Dimensions table : Dimensions of table : Tischabmessungen : Dimensiones mesa : Dimensioni tabella : Dimensões da mesa : Afmetingen tafel : ΔΙΑΣΤΑΣΕΙΣ ΤΡΑΠΕΖΙΟΥ : Wymiary stołu : Mittapöytä : Bordets storlek : Bordets mål : Dimensiuni masă :</p>	<p>Размеры стола : Tablo boyutu : Rozměr stolu : Rozmery dosky : מידת שולחן أبعاد الطاولة Az asztal mérete: Dimenzije ventilatorja: Размери на плота : Ketta suurus : Stovo matmenys : Galda izmēri : Dimenzije stola:</p>	360 x 155 mm (x2)





		0 - 3 mm
--	--	----------

	<p>90° : 0-155 mm 45° : 0-100 mm</p>	155 mm
--	--	--------

	<p>Classe d'isolement : 2 Insulation class : 2 Isolierklasse: 2 Aislamiento clase :2 Isolamento classe :2 Isolamento classe :2 Isolatie Klasse : 2 ΚΑΤΗΓΟΡΙΑ ΜΟΝΩΣΗΣ: 2 Izolacija Klazy :2 Eristysluokka :2 Isolering Klass :2 Isoleringsklasse 2 Clasă izolație :2</p>	<p>Класс изоляции 2 : Yalıtım derecesi :2 Třída izolace :2 Izolačný systém 2 Isolasjonsklasse: 2 فئة العزل :2 Szigetelési osztály :2 Razred izolacije :2 Инструмент Клас :2 Isolatsiooniklass 2 Izolācijas rūšis 2 Izolācijas klase 2 Izolacija klasa: 2</p>	X
--	---	--	---

		154,5 x 16,5 x 1,8 mm
--	--	-----------------------





 L_{pA}	Niveau de pression acoustique : Acoustic pressure level : Schalldruckpegel : Nivel de presión acústica : Livello di pressione acustica : Nivel de pressão acústica : Niveau akoestische druk : ΣΤΑΘΜΗ ΗΧΗΤΙΚΗΣ ΠΙΕΣΗΣ: Poziom mocy akustycznej : Käytä kuulosuojaimia : Ljudtrycksnivå : Lydtryk : Nivel presiune acustică :	Уровень акустического давления. : Akustik basınç seviyesi : Hladina akustického tlaku : Hladina akustického tlaku : Lydtrykknivå: مستوى الضغوط السمعي. A hangnyomás szintje : Nivo akustičnega pritiska: Равнище на акустично налягане : Helirõhu nivoo Akustinio spaudimo lygis Akustiskā spiediena līmenis Razina zvučnog tlaka:	99,7 dB (A)
--	--	--	-------------

 L_{WA}	Niveau de puissance acoustique : Acoustic power level : Schalleistungspegel : Nivel de potencia acústica : Livello di potenza acustica: Nivel de potência acústica: Niveau akoestisch vermogen : ΕΠΙΠΕΔΟ ΙΣΧΥΟΣ ΉΧΟΥ: Poziom mocy akustycznej : Käytä suojalaseja : Ljudstyrkenivå : Lydstyrke : Nivel putere acustică :	уровень мощности звука : Akustik basınç seviyesi : Hladina zvukového výkonu: Hladina zvukového výkonu: Lydeffektivität: مستوى الضوضاء. a hangnyomás szintje : Nivo akustične jakosti : Равнище на вибрации : Helivõimsuse nivoo Triukšmo lygis Akustiskās jaudas līmenis Razina zvučne snage:	114,2 dB (A)
--	--	---	--------------

NIVEAU SONORE D'ÉMISSION : A VIDE

Pression acoustique LpA poste opérateur 99,7 dB
 Incertitude 3

Puissance acoustique LWA 114,2 dB
 Incertitude 3

Valeurs déterminées suivant le code d'essai de l'annexe B de la norme EN 61029-1 avec emploi des normes de base ISO 11201 et ISO 3744.

Les niveaux de pression acoustique obtenus in situ dépendent:

- Des niveaux réels de la machine considérées, en prenant en compte les incertitudes déclarées;
- Du local et de l'installation de la machine. Préférez une pièce dont l'acoustique est plus feutrée. Evitez les pièces vides à grande résonance. Placez vous auprès d'une fenêtre le cas échéant.
- Des outils montés, des pièces travaillées, des réglages choisis,...

 L_{WA}	Niveau de vibration : Hand/arm vibration level : Vibrationspegel Hand/Arm : Nivel de vibración mano/brazo : Livello di vibrazione mano/braccio : Nivel de vibração mão/braço : Trillingsniveau hand/arm : ΕΠΙΠΕΔΟ ΚΡΑΔΑΣΜΩΝ: Poziom wibracji rózka/ramię : Tärinätaso: Vibrationsnivå hand/arm : Vibrationsniveau : Nivel vibratii :	Уровень вибрации : Titreşim seviyesi : Úroveň vibrací : Hladina vibrácií : Vibrasjonsnivå: مستوى الارتجاج. Vibrációsztint : Nivo vibracij : Равнище : Vibrācijas līmenis. Vibrācijas lygis Vibratsiooni nivo Razina vibracije:	2,6 m / s ²
--	--	--	------------------------

VIBRATIONS:

Total des valeurs de vibration (somme vectorielle des trois directions) déterminée selon EN 60745 :

a 2,6 m/s²
 Incertitude K 1,5 m/s²

L'amplitude d'oscillation peut être utilisée comme valeur de comparaison d'outils électroportatifs.
 Attention : si l'outil électroportatif est utilisé pour d'autres applications, avec d'autres outils de travail, l'amplitude d'oscillation peut être différente.





	<p>Lire les instructions avant usage : Read the instructions before use : Vor Einsatz des Geräts Anweisung lesen : Léase las instrucciones antes de usar : Leggere le istruzioni prima dell'uso : Ler as instruções antes da utilização : Lees voor het gebruik de instructies : ΔΙΑΒΑΣΤΕ ΤΙΣ ΟΔΗΓΙΕΣ ΠΡΙΝ ΑΠΟ ΤΗ ΧΡΗΣΗ: Zapoznać się z instrukcją przed użyciem : Lue ohjeet ennen käyttöä : Läs anvisningarna före användning : læs instruktionerne før brug Înainte de utilizare, citiți instructiunile :</p>	<p>Внимательно прочитайте следующие инструкции : Kullanmadan talimatları okuyunuz : Pozorně si přečtete následující pokyny : Pred použitím si prečítajte pokyny : Les bruksanvisningen før bruk: اقرأ التعليمات قبل الاستخدام. használat előtt olvassuk el az utasítást : Pred uporabo preberite ustrezna navodila Прочетете указанията за употреба : Enne kasutamist lugege instruksiooni Prieš naudojimą perskaityti instrukciją izlasīt instrukcijas pirms lietošanas Pročitati upute prije uporabe:</p>	X
---	--	---	---

	<p>Conformité européenne Conforms to EC standards : CE-Konformität : Cumples con las directivas CE : Conforme alle norme CE : Conforme às normas CE : Voldoet aan de EG-normen : ΕΥΡΩΠΑΪΚΗ ΣΥΜΜΟΡΦΩΣΗ Zgodność z normami CE : EU-standardien mukainen : Overholder EU standarderne : Conform cu normele europene:</p>	<p>соответствие европейским стандартам: Avrupa uygunluk : evropská shoda : európska dohoda : Europeisk konformitet مطابق للمواصفات الأوروبية. evropska ustreznost : európai megfeleléség : Съответствие с европейските норми : Euroopa Liidu vastavusmärk Europinių normų atitikima Atbilstība Eiropas standartiem Europska sukladnost</p>	X
---	--	--	---

	<p>Danger : Danger : Gefahr : Peligro : Pericolo : Perigo : Gevaar : ΚΙΝΔΥΝΟΣ: Niebezpieczeństwo : Vaara : Fara : Fare : Pericol :</p>	<p>Опасно : Tehlike : Nebezpečí : Nebezpečnost : Fare: خطر. Veszély : Nevarnost: Опасност : Oht Pavojus Bistamība Opasnost:</p>	X
--	--	---	---

	<p>Poids : Weight : Gewicht : Peso : Peso : Peso : Gewicht : ΒΑΡΟΣ : Masa : Paino : Vikt : Vægt : Greutate :</p>	<p>Бес : Ağırlik : Hmotnost : Hmotnosť : Vekt: الوزن. Súly : Teža : Terlo : Raskus Svoris Svars Težina</p>	8,5 kg
---	--	--	--------





	Porter des lunettes de sécurité : Wear protective eyewear : Schutzbrille tragen : Llevar puestas gafas protectoras : Portare de gli occhiali di sicurezza : Utilizar óculos de segurança : Draag een veiligheidsbril : ΦΟΡΑΤΕ ΠΡΟΣΤΑΤΕΥΤΙΚΑ ΓΥΑΛΙΑ: Zakładać okulary ochronne : Käytä suojalaseja : Använd skyddsglasögon : Der skal benyttes sikkerhedsbriller : Purtati ochelari de protectie :	Наденьте защитные очки : Güvenlik gözlükleri takın : Používejte bezpečnostní brýle : Noste ochranné okuliare : Bruk vernebriller: حَمَلْ نِظَارَاتٍ وَقَائِيَّةَ. Viseljen védőszemüveget : Nositi zaščitna očala : Да се използват защитни очила : Kandke kaitseprille Nešioti apsauginius akinius Valkät aizsargbrilles Nositi zaštitne naočale:	×
---	---	--	---

	Porter un masque anti-poussière : Wear a dust mask : Staubschutzmaske tragen : Llevar puesta una careta de protección contra el polvo : Indossare una mascherina anti-polvere : Utilizar uma máscara anti-poeira : Draag een stofmasker : ΦΟΡΕΣΤΕ ΜΑΣΚΑ ΓΙΑ ΤΗ ΣΚΟΝΗ: Zakładać maskę przeciwpyłową Käytä pölysuojust : Bär mask mot damm : Der skal benyttes beskyttelsesmaske mod støv: Purtati mască anti-praf :	Наденьте респиратор : Toza karşı maske takın : Používejte masku proti prachu : Noste ochrannú masku proti prachu : Bruk en støvmaske: لبس قناعاً مضاداً للغبار. Viseljen porvédő maszkot Nositi zaščitno masko proti prahu: Да се използва защитна маска : Kandke tolmumaski. Dėvėti respiratorių Valkät aizsarg masku pret putekliem Nositi masku za zaštitu od prašine:	×
---	--	---	---

	Porter une protection auditive : Wear hearing protective equipment: Gehörschutz tragen: Llevar puesta una protección auditiva: Portare una protezione uditiva: Utilizar uma protecção auditiva: Draag gehoorbeschermers: ΦΟΡΑΤΕ ΠΡΟΣΤΑΣΙΑ ΑΚΟΗΣ: Zakładać słuchawki ochronne Käytä kuulosuojaimia: Bär hörselskydd: Der skal benyttes høreværn: Purtati căști de protectie auz:	наденьте средства звуковой защиты: İşitsel koruma aleti takın: Používejte ochranu sluchu: Noste ochranné slúchadlá: Bruk hørselsvern: لبس خُوذة خرض الخسجي Viseljen fülvédőt Nositi zašito ušes: Да се използва слухови защитни средства: Kandke kõrvakaitset Nešioti apsaugą nuo triukšmo Valkät dzirdes aizsarglīdzekļi Nositi štitnike protiv buke:	×
---	---	--	---

	Porter des gants : Use rubber gloves : Schutzhandschuhe tragen : Llevar guantes de protección : Indossare i guanti di protezione : Utilizar luvas de protecção : Draag veiligheidshandschoenen : ΦΟΡΩΝΤΑΣ ΓΑΝΤΙΑ: Używać rękawic ochronnych : Käytä suojakäsineitä : Använd skyddshandskar : Der skal benyttes handsker : Purtati mănuși :	Наденьте перчатки : Eldiven takın : Noste rukavice : Noste rukavice : Bruk hansker: لبس قفازات. Viseljen kesztyű t Nositi rokavice: а се използват предпазни ръкавици : Kandke kindaid Müvėti pirštines Valkät cimds Nositi zaštitne rukavice:	×
---	--	--	---





	<p>Soumis à recyclage Subjected to recycling Sujeto a reciclaje Sottoposti a riciclaggio Sujeitos à reciclagem Não deite no lixo : Niet wegwerpen : ΥΠΟΚΕΙΤΑΙ ΣΕ ΑΝΑΚΥΚΛΩΣΗ Nie wyrzucac : Älä heitä pois luontoon : Batteriet får inte kastas : Bortkast det ikke: Nu le auncati :</p>	<p>Подлежит переработке Atmayingiz : Nevyhadzujte je do bežného odpadu : Neodhadzovat : Gjenvinningspliktig فلا ترمدها دلذا في القمامة. ne mečíte1 Ne odvržite ga/jih vstran : Taaskasutusse kuuluv Ärge visake seda minema : Nemetykíte : Nemest : Podvrgnuto recikliranju</p>	×
---	---	---	---

Recyclage des déchets :

Les outils, accessoires et leur emballages doivent suivre une voie de recyclage adaptée. Conformément aux directives Européenne 2012/19/UE et 2006/66/CE, les composants d'un produit doivent être séparés, collectés, recyclés ou éliminés en conformité avec les réglementations environnementales en vigueur. Les appareils, batteries, piles, huiles, emballages devront être déposés dans les systèmes d'élimination des déchets spéciaux tels que déchetteries. Renseignez-vous auprès de votre commune pour connaître l'organisme le plus proche à même de retraiter ou de collecter ces déchets.

	<p>Recyclable, soumis au tri sélectif Recyclable, subject to recycling Recyclingfähige, unterliegen Recycling Reciclables, sujetos a reciclaje Riciclabili, soggetti a riciclaggio Recicláveis, sujeito à reciclagem Recycleerbare, onderworpen aan recycling ΑΝΑΚΥΚΛΩΣΙΜΟ, ΥΠΟΚΕΙΤΑΙ ΣΕ ΕΠΙΛΕΚΤΙΚΗ ΔΙΑΛΟΓΗ Opakowanie nadaje się do recyklingu podlegają recyklingu Kierrätettävien pakkausten kohteena kierrätys Återvinningsbara förpackningar omfattas återvinning Рециклираци се опаковки подлежат на рециклиране Genanvendelig underlagt genbrug</p>	<p>Reciclabile sub rezerva reciclare Повторно упаковка подлежит вторичной переработке Gerí dönüŝüm Geri dönüŝtürülebilir ambalaj konusu Recyklovateľné podléhajúci recyklácii Recyklovateľné podliehajúce recyklácii Resirkulerbar, med förbehold om selektiv sortering ريودتلل هدا عيال ريويرت ريودتلل هدا عيال هلابانوا فبال عيال او قوب عيال Újrahasznosítható csomagolás alá újrahasznosítás Reciklirati predmet recikliranja Pakendite suhtes ringlussevõtu Pärsträdājams iepakojuoms otrreizējai pārstrādei Perdirbamų taikomos perdirbimo Može se reciklirati, podložno selektivnom sortiranju</p>	×
---	--	---	---





RB 1800D

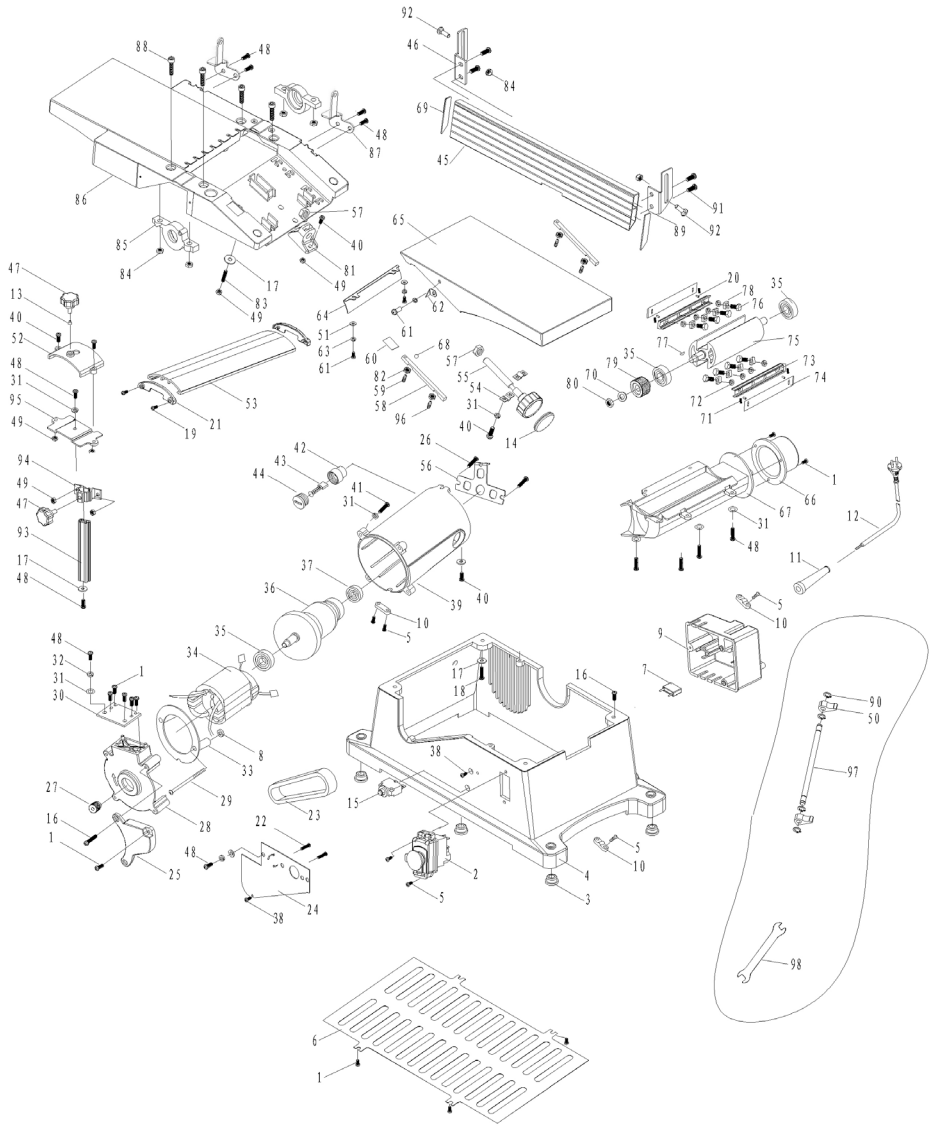

DECLARATION DE CONFORMITE
VERKLARING VAN OVEREENSTEMMING
DECLARACION DE CONFORMIDAD
DICHIARAZIONE DI CONFORMITA
KONFORMITÄSERKLÄRUNG
DECLARATION CONFORMITY
DECLARAÇÃO DE CONFORMIDADE
DEKLARACJA ZGODNOSCI Z NORMAMI
OM ÖVERENSSTÄMMELE
VAATIMUSTENMUKAISUUSVAKUUTUS
OVERENSSTEMMELSESERKLÆRING
Δήλωση συμμόρφωσης/συμμόρφωσης

DECLARAȚIE DE CONFORMITATE
VYHLÁSENIE ZHODY
Декларация соответствия
הצהרת תואמת
Uygunluk beyanı
التصريح بالخطابفة
PROHLÁŠENÍ SHODY
EGYZEZŐSÉGI NYILATKOZAT
Декларация за съответствие с нормите
IZJAVA O SKLADNOSTI
DECLARACIA
ΑΠΤΙΚΤΗΣ DEKLARACIA
KINNITUS
IZJAVA O SUKLADNOSTI

Le soussigné,
Ondergetekende,
Der Unterzeichner,
O abaixo assinado,
Undertecknad,
Долуподписаният
Undertegnede
Subsemnatul,
Я, нижеподписавшийся,
Imzalayan,
Niže podepsany,
Toliau pasirašęs

Declare par la présente que,
Verklaart hiermede dat,
Erklärt hiermit daß,
Declaro pela presente que,
Förklarar härmed att
Заявляю с настоящото
erklærer hermed, at
Declar prin prezenta că,
настоящим подтверждаю, что
Mevcut belgeyle beyan ediliyor ki,
tımto proflaşıje, že,
Pareiškia, kad,

Personne autorisée à constituer
le dossier technique :
Christophe HUREL



FAR GROUP EUROPE
192, Avenue Yves Farge
37700 St. Pierre-des-Corps
FRANCE

El suscrito,
Il sottoscritto,
The undersigned,
Ninej podpisany
Allékirjoittanut,
Ουπτογεγραμμένοζ
Nižšie podpisany
החתום מטה,
الذوق أدناه,
Alulírott,
Podpisani,
Apakšā parakstjies
allakirjutanu
Dolje potpisani,

Declaro por la presente, que,
Dichiare che,
Declares that,
Oświadczam niniejszym, że
Ilmoitetaan täten että,
Δηλώνω με την Παράστα
tımto vyhlasuje, že
מצהיר בזה כי
يصرح استنادا على ذلك
kijelentem, hogy a készülék Izjavlja da,
Pareiškia, kad,
Ar šio apliecinā, ka,
Kinnitab, et
Izjavljuje u ovom dokumentu da je

Dégauchisseuse/ jointer / Elektrohobel / Piaalla elettrica / Piaalla a filo / Maquina de Aplainar / Elektrische Schaafmaschine /
Hlektrikb Píanh / Strugarka Elektryczna / sáhköhövlá / elhyvel / Elektrischeso rende. / Elektrisk høvl / Rindea electrică /
Электрический струг / Elektrikli rende / Elektrický hoblík / Elektrický hoblík / תילמשור העטקמ / جئالبرده رتتم / Elektromos gyalu
/ Električni oblič / Freesimispink / Stacionară évele / Stacionarus oblius

code

FARTOOLS / 113395 / RB 1800D / M1B-LS-1558

Est conforme et satisfait aux directives et normes CE,
In overeenstemming is met en Voldoet aan EG richtlijnen,
Den folgenden EU-Bestimmungen entspricht,
Respeita e está em conformidade com as normas CE,
Överensstämmer med och uppfyller EG-standarder,
Съответства и отговоря европейските норми
Er i overensstemmelse med og overholder EU standarderne
Este conform și satisface normele CE
полностью соответствует и удовлетворяет
требованиям стандартов ЕС
CE şartlara uygundur,
odpovídá normám ES.
Atitinka ir atitinka EB direktyvas ir standartus,

Cumple con la directivas de la CE,
E conforme alle direttive CEE,
Complies with the EEC directives and standards,
Odpowiada normom UE,
Täytää EU-vaatimukset,
Είναι συμμόρφωνο και ανταποκρίνεται στα Πρότυπα CE
zodpovedá normám ES.
מתאים ועונה לתקני CE
بان الهاز يطابق و يالبي معايير مجموعة الدول الأوروبية
kielégíti a CE szabványok előírásait.
Je v skladu z in izpolnjuje norme Evropske skupnosti.
Atbilst un atbilst EK direktīvas un standartus,
Vastab ja vastab EU direktīviudele ja standarditele,
Sukladan i ispunjava direktive i standarde CE,

Attestation de type (EC type) N° BM50330730001

Rapport (report) N° 14717618003

TUV Rheinland LGA Products GmbH · Tillystraße 2 · 90431 Nürnberg
Accredited by Zentralstelle der Länder für Sicherheitstechnik (ZLS).
Notified under No. 0197 to the EC Commission.

2014/30/EU 2006/42/EC 2011/65/EU 2015/863/EU

EN 61029-1:2009+A11
EN 61029-2-3:2011
EN IEC 55014-1:2021
EN IEC 55014-2:2021
EN IEC 61000-3-2:2019+A1+A2
EN IEC 61000-3-11:2019

Christophe HUREL,
Directeur général
07/05/2025
Fait à St. Pierre-des-Corps



GARANTIE - WARRANTY



FR. GARANTIE

Cet outil est garanti contractuellement contre tout vice de construction et de matière, à compter de la date de vente à l'utilisateur et sur simple présentation du ticket de caisse. La garantie consiste à remplacer les parties défectueuses. Cette garantie n'est pas applicable en cas d'exploitation non conforme aux normes de l'appareil, ni en cas de dommages causés par des interventions non autorisées ou par négligence de la part de l'acheteur. La garantie ne s'applique pas sur les dommages causés par une défaillance de l'outil.

DE. GARANTIE

Die Garantiezeit für dieses Gerät in Bezug auf Konstruktions- und Materialfehler beträgt lt. Vertrag bei Vorlage des Kassensbons. Die Garantieleistung besteht im Ersatz schadhafter Teile. Die Garantie erlischt bei einem Einsatz des Geräts, der nicht normentsprechend ist, bei Schäden, die auf unsachgemäße Eingriffe zurückzuführen sind bzw. bei Nachlässigkeit seitens des Käufers. Die Garantie erstreckt sich nicht auf Schäden, die auf Fehlfunktionen des Geräts zurückzuführen sind.

IT. GARANZIA

Quest' attrezzo è garantito per contratto contro qualsiasi difetto di costruzione e di materia, a partire dalla data di vendita all' utente e su semplice presentazione dello scontrino. La garanzia consiste nel sostituire le parti difettose. Questa garanzia non è applicabile in caso di sfruttamento non conforme alle norme dell' apparecchio, né in caso di danni causati da interventi non autorizzati o da negligenza da parte dell' acquirente. La garanzia non si applica ai danni causati da un avaria dell' attrezzo.

EN. GARANTIE

This tool is guaranteed, in writing, against any defect in manufacture or parts from the date of sale, upon simple presentation of the sales slip. The guarantee is limited to the replacement of faulty parts. This guarantee is not applicable in the event of usage which is not conform with the intended usage of the apparatus, nor in the event of damage caused by unauthorised servicing or negligence on behalf of the purchaser. This guarantee does not apply to any damage caused by

the failure of this tool.

ES. GARANTIA

Esta herramienta se garantiza contractualmente contra todo defecto de construcción y materia, a partir de la fecha de venta a l' usuario y sobre simple presentación del recibo de caja. La garantía consiste en sustituir a las partes defectuosas. Esta garantía no es aplicable en caso de explotación no conforme a las normas del aparato, ni en caso de daños causados por intervenciones no autorizadas o por negligencia por parte del comprador. La garantía no se aplica sobre los daños causados por un fallo del herramienta.

NL. GARANTIE

Dit gereedschap heeft een garantie tegen constructiefouten en materiaaldefecten, die geldig is vanaf de aankoopdatum door de gebruiker, op vertoning van de kassabon. De garantie betreft de vervanging van de defecte onderdelen. Deze garantie is niet van toepassing indien het apparaat niet volgens de normen gebruikt is, noch in geval van schade veroorzaakt door oneigenlijk gebruik of nalatigheid van de koper. De garantie is niet van toepassing op schade voortvloeiend uit een defect van het gereedschap.

PT. GARANTIA

Esta ferramenta tem uma garantia contratual contra qualquer defeito de construção e de material, a partir da data de venda ao utilizador e sobre simples apresentação do talão da caixa. A garantia consiste em substituir as partes defeituosas. Esta garantia não é aplicável no caso de exploração não conforme as normas do aparelho, nem em caso de danos causados pelas intervenções não autorizadas ou por negligência da parte do comprador. A garantia não se aplica para os danos causados por uma falha da ferramenta.

EL. ΕΓΓΥΗΣΗ

ΑΥΤΟ ΤΟ ΕΡΓΑΛΕΙΟ ΕΙΝΑΙ ΣΥΜΒΑΤΙΚΑ ΕΓΓΥΗΜΕΝΟ ΓΙΑ ΟΤΙΟΙΟΝΔΠΟΤΕ ΚΑΤΑΣΚΕΥΑΣΤΙΚΟ ΚΑΙ ΥΛΙΚΟ ΕΛΑΤΤΩΜΑ, ΑΠΟ ΤΗΝ ΗΜΕΡΟΜΗΝΙΑ ΠΩΛΗΣΗΣ ΣΤΟΝ ΧΡΗΣΤΗ ΚΑΙ ΜΕ ΤΗΝ ΕΠΙΔΕΙΞΗ ΤΗΣ ΑΠΟΔΕΙΞΗΣ ΠΩΛΗΣΗΣ. Η ΕΓΓΥΗΣΗ ΣΥΝΙΣΤΑΤΑΙ ΣΤΗΝ ΑΝΤΙΚΑΤΑΣΤΑΣΗ ΤΩΝ ΕΛΑΤΤΩΜΑΤΙΚΩΝ ΕΞΑΡΤΗΜΑΤΩΝ. ΑΥΤΗ Η ΕΓΓΥΗΣΗ ΔΕΝ ΙΣΧΥΕΙ ΣΕ ΠΕΡΙΤΤΩΣΗ ΛΕΙΤΟΥΡΓΙΑΣ ΠΟΥ ΔΕΝ ΣΥΜΜΟΡΦΩΝΕΤΑΙ ΜΕ ΤΑ ΠΡΟΤΥΠΑ ΤΗΣ ΣΥΣΚΕΥΗΣ, ΟΥΤΕ ΣΕ ΠΕΡΙΤΤΩΣΗ ΖΗΜΙΑΣ ΠΟΥ ΠΡΟΚΑΛΕΙΤΑΙ ΑΠΟ ΜΗ ΕΟΥΣΙΟΔΟΤΗΜΕΝΕΣ ΕΠΕΜΒΑΣΕΙΣ Ή ΑΜΕΛΕΙΑ ΕΚ ΜΕΡΟΥΣ ΤΟΥ ΑΓΟΡΑΣΤΗ. Η ΕΓΓΥΗΣΗ ΔΕΝ ΙΣΧΥΕΙ ΓΙΑ ΖΗΜΙΕΣ ΠΟΥ ΠΡΟΚΑΛΟΥΝΤΑΙ ΑΠΟ ΑΣΤΟΧΙΑ ΕΡΓΑΛΕΙΟΥ.

PL. GWARANCJA

Narz dzie, jest objte gwarancja na wszelkie wady konstrukcyjne i materiałowe, licząc od daty

sprzedaży u użytkownikowi i po okazaniu paragonu kasowego. Gwarancja obejmuje wymianę cz. Aci wybrakowanych. Gwarancja nie znajduje zastosowania w przypadku użycowania niezgodnego z normami urządzenia, ani w przypadku szkód spowodowanych działaniami niedozwolonymi lub zaniebdaniami ze strony nabywcy. Gwarancja nie obejmuje szkód powstałych z powodu upadku urządzenia.

SV. GARANTI

Detta verktyg har en avtalsenlig garanti mot konstruktions- och materialfel, från och med tidpunkten för användarens inköp och genom uppvisning av kassakvittot. Garantin består i att ersätta de bristfälliga delarna. Denna garanti gäller inte om användningen inte motsvarar apparatens standarder, inte heller vid skador som orsakas av ej tillåtna ingrepp eller på grund av koparens vårdslöshet. Garantin gäller inte forskador som orsakats av att verktyget fungerat bristfälligt.

FI. TAKUU

Tämän laitteen takuu on voimassa sopimuskumukaisesti kattaen kaikki rakenne- ja materiaaliiviat lukien ostopaivasta kassakuittia vastaan. Takuu sisältää viallisten osien korvaamisen, Takuu ei korvaa ohjeiden vastaista käyttöä eikä valtuuttamattomien henkilöiden kasittelyä tai ostajan huolimattomuudesta aiheutuneta vahinkoa. Takuu ei vastaa myöskään toimintahairiosta aiheutuneta vahinkoa.

BU. Гаранция

Този инструмент е под договорна гаранция срещу всякакъв дефект в изработката и използваните материали, считано от датата на продажба на потребителя и само срещу представяне на касовата бележка. Гаранционното обслужване се състои в замяна на дефектните части. Настоящата гаранция не е валидна когато апаратът се използва по начин, несъответстващ на стандарта за работа с него, както и в случай на щети, нанесени от неоторизирани лица, или вследствие на проявена небрежност от страна потребителя.

Гаранцията не покрива щети, произтекли вследствие на техническа неизправност на апарата.

DA. GARANTI

Dette værktøj er dækket af en garantikontrakt for konstruktions- og materialefej, som gælder fra købsdatoen ved visning af kassebonen. Garantien består i at udskifte de defekte dele. Garantien dækker ikke fejl opstået som følge af anvendelse, som ikke overholder standarderne for apparatet, eller

SERVICE APRÈS VENTE - AFTER SALE SERVICE

FARGROUP EUROPE - 192, Avenue Yves Farge - 37700 St. Pierre-des-Corps - FRANCE

fargroup@fargroup.net



skader opstået ved ikke autoriserede indgreb eller sløsethed fra brugerens side. Garantien dækker ikke skader opstået, fordi værktøjet har svigtet.

RO. GARANTIE

Acest aparat este garantat din punct de vedere contractual împotriva tuturor viciilor de construcție și de material, începând de la data vânzării lui către utilizator și la simpla prezentare a bônului de casă. Garanția constă în înlocuirea componentelor defecte. Această garanție nu se aplică în cazul exploataării în alt mod decât cel recomandat de normele aparatului și nici în caz de stricăciuni provocate de intervenții neautorizate sau prin neglijența cumpărătorului. Garanția nu se aplică asupra pagbelor cauzate de o defectare a aparatului.

RU. ГАРАНТИЯ

Данное изделие обладает имеющей силу контракта гарантией, покрывающей все возможные дефекты изготовления и материала. Гарантия вступает в силу с даты продажи изделия пользователю, для этого достаточно сохранить и предъявить полученный в кассе чек. Гарантия обязывает изготовителя заменить дефектные части изделия. В случае не соответствующего нормам использования изделия, несанкционированного демонтажа или ремонта или небрежного обращения действие гарантии прекращается. Гарантия не покрывает ущерба, возникшего в результате сбоя в работе изделия.

TU. GARANTI

Bu arac, satis tarihinden itibaren, kullanıcının sâdece vezne alınırsını sunmasıyla tüm üretim ve malzeme hatâsına karşı garantilidir. Garanti eksik olan kisimlari degistirmek icindir. Bu garanti aracın sartlarına uygun olmayan isleme durumunda, izin verilmeyen kullanimlardan kaynaklanan hasarlarda veya alicinin istegi durumunda uygulanmaz. Garanti malzemenin bir eksikliginden meydana gelen bir zararda uygulanmaz.

CS. ZÁRUKA

Pro tento nástroj platí smluvní záruka na všechny výrobní a materiálové vady od data prodeje uživateli a na základě predložení pokladniho bloku. Záruka spočíva ve výmene vadných častí. Táto záruka neplatí v prípade použitia prístroja, ktoré

neodpovídá normám, ani v případě škod způsobených nepovolenými zásahy nebo nedbalostí ze strany kupujícího. Záruka se nevztahuje na škody způsobené závadou nástroje.

SK. ZÁRUKA

Pre tento nástroj platí zmluvná záruka na všetky výrobné a materiálové chyby od dátumu predaja užívateľovi a na základe predloženia pokladničného bloku. Záruka spočíva vo výmene chybných častí. Táto záruka neplatí v prípade použitia prístroja, ktoré nezodpovedá normám, ani v prípade škod spôsobených nepovolenými zásahmi alebo nedbalosťou zo strany kupujúceho. Záruka sa nevztahuje na škody spôsobené poruchou nástroja

AR. الضمان

في لعتي ءارشالفاقظ مبيدقت درجم بلع ءانبو بعنسملا بلا عيلا خيرات نم اراينعا بءاوملايفوع ينصتلا يف بيع نم ايداعا قنومضم مد علا هذه نا تافاللتال هضرعت ءلاحيق الو بزاهجلا زيباعمل قنابملا ربع مارختسالا ءلاخ يف قنيطال الباق نامضلا اذء نوكي ال قنابملا ءلاخ يف لاديسن ياف نامضلا للء نع حناتلا ررضلا بلع نامضلا قنطني ال يرشملا لبق نم لامهالا ءلاخ يف وا قنصخرم ربع لحدت تابلعم نع مءجان

HU. GARANCIA

Erre a szerszámra szerződéses garanciát vállalunk bármilyen gyártási és anyaghiba felmerülése esetére, a fogyasztó részére történt eladás napjától számítva, a penztári blokk egyszerű felmutatása elleneben. A garancia a hibás alkatrészek cseréjére terjed ki. Ez a garancia nem érvényes, ha a készüleket nem rendeltetésszerűen használták, sem illetéktelen beavatkozások vagy a vásárló hanyagsága okozta károk esetén. A garancia nem fedezi azokat a károkat melyeket a szerszám hibás működése okozott.

SI. GARANCIJA

To orodje je z garancijsko pogodbo zasciteno proti vsem napakam v izdelavi in v sestavnem materialu od datuma prodaje naprej in ta velja ob predložitvi blagajniškega racuna. Garancija velja za zamenjavo delov z napako. Ta garancija ne velja za uporabo orodja, ki ni v skladu z normami, predpisanimi za omenjeno orodje in za primere okvar, ki nastanejo zaradi nedovoljenih posegov na orodju ali zaradi malomarnega rokovanja kupca. Garancija ne velja za škodo, ki jo lahko povzroci okvara orodja.

ET. GARANTII

See tööriist kuulub lepingu järgi garantiiremonti arvestades alates muumise päevast ja kassatseki alusel kasutajale kõigi konstruktsiooni- ja materjalvigade puhul. Garantii seisneb defektsete osade välja-

vahetamises. See garantii ei kehti aparaadi normide ebatavalises eiramise puhul ega ostja poolt keelatud viisil, kasutamisesest või hooletusetahtmisest tulenevate kahjude korral. Garantii ei kehti seadme defektidest põhjustatud kahjude puhul

LV. GARANTĪJA

Šis prietaisys yra uztiķināmas kāp itin ģeros kokybēs, nūo jo pārdavimā datos iki jo pānaudojimo, ir jam yra suteikiamas garantinis talons. Garantijos metu galima pakeisti atsiradusius trumplaiķius gedimus. Si garantija netaikoma esant netinkamam naudojimui ar nesilaikant reikiam šio aparato vartojimo instrukcijų, tai pat paciam pirkeiui jį sugadinus. Garantija taip pat netaikoma, prietaisa naudojant ne pagal paskirti jį jį apgadinus

LT. GARANTIJA

Šim darbaram ir liguma noteikta garantija visiem defektiem, kas saistās ar konstrukciju un materiālu, sākot ar pārdošanas datumu, kad masiņu pārdod lietotājam un vienlaīši uzrādod kases ceķu. Garantija iekļauj bojāto daļu nomaiņu. Si garantija nav derīga, ja aparāts nav lietots saskaņā ar drošības noteikumiem, ne gādājums ja bojājumi radusies nesankcionētās iekļaušanas gādījumā vai arī pierceja nolaidības dēļ. Garantija nav derīga, ja bojājumi radusies darbbarika defekta dēļ

HR. JAMSTVO

Ovaj alat ima ugovorno jamstvo u slucaju bilo kakvih nedostataka u konstrukciji i materijalu, od datuma prodaje korisniku uz jednostavno predocenje racuna. Jamstvo se sastoji u zamjeni neispravnih dijelova. Ovo se jamstvo ne primjenjuje u slucaju uporabe i eksploatacije koja nije sukladna standardima uređaja, niti u slucaju štete uzrokovane neovlaštenim intervencijama ili neomarnom kupca. Jamstvo se ne primjenjuje na štetu uzrokovanu nekim nedostatkom alata.

SERVICE APRÈS VENTE - AFTER SALE SERVICE

FARGROUP EUROPE - 192, Avenue Yves Farge - 37700 St. Pierre-des-Corps - FRANCE
fargroup@fargroup.net



FAR GROUP EUROPE

Une société du groupe **SIGMA**

192, Avenue Yves Farge
37700 St. Pierre-des-Corps
FRANCE

fartools.com

